

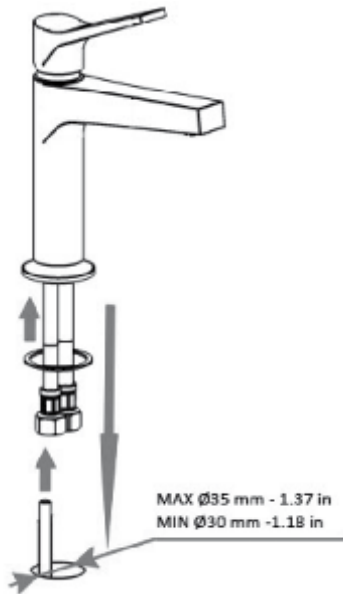

# TW 200 - 220

## Step 01



## Step 02

